

INSTRUCTIONS

Recessed Light – 240v

DuoMarka, QuadMarka, Linalite, Caverna



WARNINGS



PLEASE READ THESE INSTRUCTIONS CAREFULLY BEFORE COMMENCING ANY WORK

- If a fitting is found to be damaged, cease use immediately.
- This is a Class I product and must be earthed
- This unit must be fitted by a competent and qualified electrician.
- Install in accordance with IEE wiring regulations and current Building Regulations.
- To prevent electrocution, switch off mains supply before installing or maintaining this fitting. Ensure other persons cannot restore the electrical supply without your knowledge.
- This light fitting should be connected to a circuit with a 30Ma RCD fitted. Maximum 12-15 fittings on each circuit recommended.
- If replacing an existing fitting, make a careful note of the connections.
- All connections should be made watertight to avoid electrical shortage.
- When changing the bulb, always switch off at the mains & allow to cool before handling.
- Always use the correct type & wattage bulb. Never exceed the wattage stated.
- The unit may get warm whilst on for a period of time.
- **DO NOT INSTALL WITHOUT MOUNTING SLEEVE**

Voltage: 220 - 240v 50Hz

Max. Wattage: 35w

Bulb Holder: GU10 (lamp sold separately– LED recommended)

IP Rating: IP67

Cable: 3 core rubber cable 0.75mm (length may vary)

Mounting Sleeve: ABS Thermoplastic (removable)

Mounting Hole Size: 70mm + 2 x 9mm overlap

NOTES

Will accommodate longer than average GU10s



**2 YEAR
GUARANTEE**

see website for
more details



SILICA GEL & O-RINGS (DO NOT REMOVE):

A small pack of silica gel has been included with this recessed light, located inside with the bulb holder. This should **not** be removed. Condensation inside the light is inevitable due to the warm bulbs and cold weather conditions, especially if installed on a damp day. The pack of silica gel will collect the moisture inside the fitting, preventing this from happening. It is recommended that the silica gel is replaced when the light bulb is replaced, if not before, and the white rubber o-ring checked. This should be replaced if there are any signs of damage – a spare is provided with each fitting.

CLEANING:

Occasional cleaning and care is recommended for this product. Please refer to our website for the best way to clean different materials.

RETURNS:

Please contact us by phone or email

Lumena Lights Ltd, Centre 33 Long March, Daventry, Northants, NN11 4NR

Tel: +44 1327 871161 Fax: 0800 066 4410 Email: sales@lumenalights.com

Instructions accurate at time of printing. Check for updates by visiting our website.

Producer Registration Number: **WEE/KC3440XY**

Full product range & more information: www.lumenalights.com



MOUNTING:

IMPORTANT: The mounting sleeve must be used as this adds protection to the fitting and the large rubber seal adds to the ingress protection. If the mounting sleeve is not used, the Guarantee will be void.

- Drill out installation hole in the desired location (see diagram). Allow for at least 131mm depth for the 70mm hole to accommodate the length of the mounting sleeve. 2 x 9mm Lug holes need only be drilled to 30mm depth if screwing in position.
- Alternatively, the 2 x lugs can be cut off carefully with a sharp knife. This would result in a simpler 70mm installation hole but allow the fitting to spin after installation.
- Secure the mounting sleeve in place with either 2 x 40mm M4 screws through the lugs OR use waterproof glue / sealant around the underside of the rim and allow to dry.
- Connect to the power supply (see below).
- Install lamp (see below).
- Ensure the large white rubber seal is in place, just covering the join of the top and bottom of the fitting from below (see image)
- Push the fitting into the mounting sleeve which is firmly held in position by the rubber seal surrounding the join of the fitting.

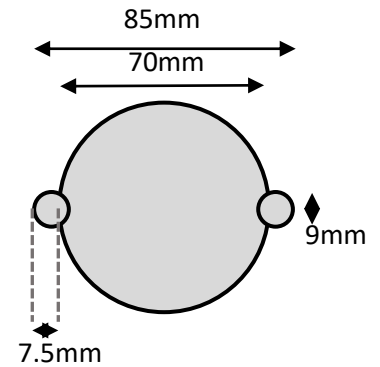

WIRING / CONNECTION:

Always use a waterproof Junction Box or Tubecon Connector to connect the fitting to the mains power supply.

IMPORTANT: Cable should be laid inside armoured conduit or piping to protect from water-logging, chemicals found in soil and damage. If buried, it should be buried to at least 0.5m below ground to reduce damage risk. If this method is not used, cable warranty will be void.

- Locate the mains electrical supply (pre-installed).
NOTE: Outdoor 240v cable must be armoured or protected by armoured conduit. If buried, it should be buried to at least 0.5m below ground to reduce damage risk.
- Connect the fitting to the mains supply via a waterproof junction box or Tubecon connector (see diagram for wiring information).
- Ensure all terminals of the connector block are secure with no stray wires and that the connection is watertight.
- Cable supplied with fitting is not armoured, therefore it should be laid inside armoured conduit or hooked up safely out of reach in protective piping.
- Once fully installed, including the GU10, turn on the mains power.

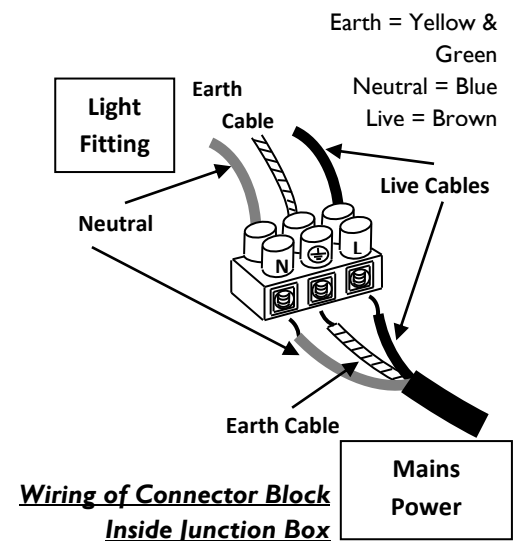

LAMP INSTALLATION / REPLACEMENT:

IMPORTANT: A clear rubber o-ring must be present between the Cap and Body of the Recessed Light to ensure a watertight join. If for any reason this is missing, please contact us for a replacement (a spare is usually provided).

- Pull the light up and out of the protective mounting sleeve
- Unscrew the Cap (top section) of the Recessed Light
- Insert the GU10 into the greased bulb holder with a push and twist locking action – please refer to our GU10 Waterproofing Procedure Guidelines attached.
- Ensure the silica gel pouch is still located inside the fitting to prevent condensation build up (replace pack if required).
- Ensure the white rubber o-ring is in place between the Head Cap and Base and not twisted for a watertight seal.
- Replace the cap and tighten securely.

NOTE: Condensation is likely to occur due to the warmth inside the fitting produced by the lamp and the cold air outside. If this is noticed, on a dry day, turn off the power supply, safely remove the cap and wipe dry with a soft cloth. Replace the silica pouch as and when required. The GU10 waterproof procedure should protect the bulb holder from condensation and short circuiting.