

THANK YOU FOR YOUR PURCHASE
PLEASE READ THESE INSTRUCTIONS CAREFULLY PRIOR TO INSTALLATION / MAINTENANCE

SPECIFICATIONS

Voltage: 220-240v
Max Wattage: 50W
Bulb Holder: GU10 (lamp sold separately)
IP Rating: IP54
Cable Type: 0.75mm 3 Core H05RN-F (open end)
Cable Length: Approx. 5m
Materials: Solid Brass / Toughened Glass
Lens: Glass (Convex) with Glare Shield
Weight: 0.95KG (approx.)
Mounting: Internal Surface Mount (supplied)
Adjustable: Yes (serrated clamp joint)
Mounting Thread: 21mm
Mounts & Accessories Available: Ground Spike, Surface Mount, Tree Bracket, Wall Mount, Extension Poles

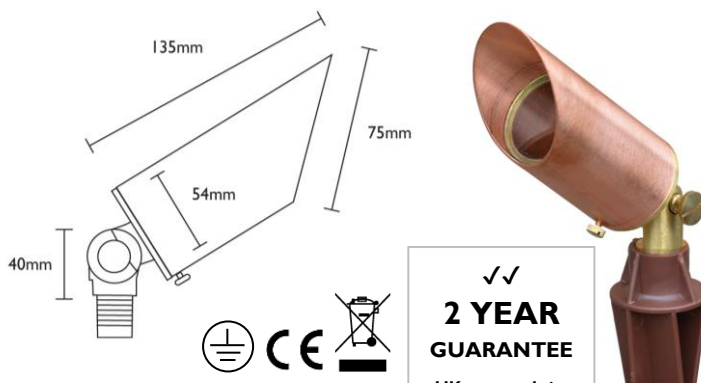

✓✓
2 YEAR
GUARANTEE
 UK - see website
 for more details

WARNINGS



- If a fitting is found to be damaged, cease use immediately.
- This is a Class I product and must be earthed
- Install in accordance with the IEE Wiring Regulations and Building Regulations. If in doubt, consult a qualified electrician.
- To prevent electrocution, switch off mains supply before installing or maintaining this fitting. Ensure other persons cannot restore the electrical supply without your knowledge.
- This light fitting should be connected to a circuit with a 30Ma RCD fitted. Maximum 12-15 fittings on each circuit recommended.
- If replacing an existing fitting, make a careful note of the connections.
- All connections should be made as watertight as possible to avoid electrical shortage.
- When changing the bulb, always switch off at the mains & allow to cool before handling.
- Always use the correct type & wattage bulb. Never exceed the wattage stated.
- The unit may get warm whilst on for a period of time.

SILICA GEL & O-RINGS (DO NOT REMOVE):

A small pack of silica gel has been included with this spike light, which is to be located inside the head with the bulb holder. This should **not** be removed. Condensation inside the spike light is inevitable due to the heat generated from lamps and cold weather conditions, especially if installed on a damp day. The pack of silica gel will collect the moisture inside the fitting, preventing this. It is recommended that the silica gel is replaced when the light bulb is replaced, if not before, and the rubber o-rings checked. This fitting should not be used if there are any signs of damage.

CLEANING:

Occasional cleaning and care are recommended for this product. Wipe with a soft, slightly damp cloth to remove any surface dirt. Do not use abrasive cleaners or a lot of water as this could damage the fitting. Please refer to our website for more information on the best way to clean different materials.

RETURNS & DISPOSAL: (Our full returns policy is available on our website)

If purchased from a 3rd party, please contact your supplier. If purchased direct, contact us by phone or email:
 Lumena Lights Ltd, Centre 33 Long March, Daventry, NN11 4NR Tel: +44 1327 871161 Email: sales@lumenalights.com

Waste Electrical Products should not be disposed of with household waste. Please check with your local authority or contact us for more information. Please recycle packaging wherever possible. **Producer Registration Number: WEE/KC3440XY**

Full product range & more information: www.lumenalights.com

INSTALLATION:

- Attach the fitting to the relevant mount by threading the cable through the mount and then screwing onto the threaded base (clockwise). Ensure the cable is spinning freely with the fitting or it will twist and could damage the internal connection.
- Install the mount in position (see below).
- Wire fitting to the mains (see below).
- Adjust the angle of the spotlight by loosening the brass serrated clamp joint screw, adjusting head, tightening brass screw securely in position. Always ensure the glare shield is at the top of the fitting.

GROUND SPIKE

- Dampen the Ground where the fitting is to be installed – ensure there is enough cable slack.
- Once the fitting is attached to the spike, push firmly into the ground (do not put pressure on the end of the head or it could damage the serrated clamp joint, put pressure only in line with the mount at the back of the head. If there is a lot of resistance, soften the ground further prior to installation and change location.

SURFACE MOUNT / WALL MOUNT

- Use the pre-drilled holes of the mount as a guide.
- Mark the mounting holes in the desired location.
- Fix in place with fixings relevant to the materials of location e.g. wood screws / wall plugs & screws (not supplied).

WIRING / CONNECTION:

Always use a waterproof Junction Box or Tubecon Connector to connect the fitting to the mains power supply.

IMPORTANT: Cable should be laid inside armoured conduit or piping to protect from water-logging, chemicals found in soil and damage. If buried, it should be buried to at least 0.5m below ground to reduce damage risk. If this method is not used, cable warranty will be void

- Locate the mains electrical supply (pre-installed armoured cable).
- Ensure the mains power is switched off.
- Connect the fitting to a connector block located inside a waterproof junction box or a single waterproof in-line connector such as the Tubecon (sold separately)
- Ensure all terminals of the connector block are secure with no stray wires and that the connection is watertight.
- Seal the junction box to ensure a watertight seal.
- Once fully installed, turn on the mains power.

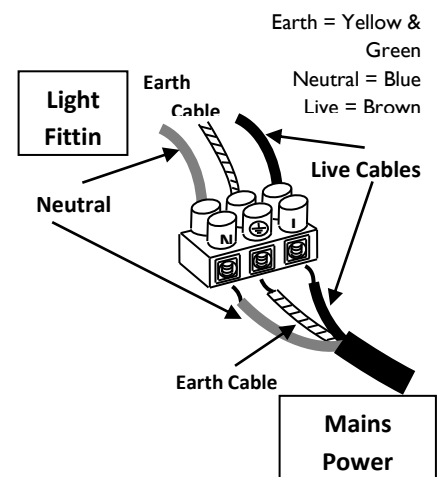

LAMP INSTALLATION / REPLACEMENT:

- Remove the front cap by removing the brass grub screw on the underside of the head (anticlockwise), then pull then head off, over the 2 rubber o-rings grippers / seals.
- Insert GU10 lamp (push and lock action) – bulb holder will be greased. We recommend this is re-done on every lamp change.
- Replace the front cap and secure (as above) ensuring the seal is in place and the fitting is closed completely and evenly.

IMPORTANT: Condensation may occur due to the warmth inside the fitting produced by the lamp and the cold air outside. If this is noticed, on a dry day, turn off the power supply, safely remove the front plate and wipe dry with a soft cloth. A silica gel pouch can be left inside the fitting to soak up any excess moisture if required.

TROUBLESHOOTING:

If for any reason the fitting does not work after installation, please follow the below steps safely (power supply must be off):

- Check that all connections are correct and secure
- Check the cable and bulb holder for damage
- Change the LED bulb, double checking that it does not exceed the maximum wattage

If the fitting stops working after a period of time, please follow the above steps with the addition on the following:

- Check the fitting and the junction box for damage or water ingress

If none of the above rectifies the issue, please contact us for further assistance.

Full product range & more information: www.lumenalights.com