



WARNINGS



PLEASE READ THESE INSTRUCTIONS CAREFULLY PRIOR TO INSTALLATION / MAINTENANCE

- If a fitting is found to be damaged, cease use immediately.
- This is a Class I product and must be earthed.
- This unit must be fitted by a competent and qualified electrician.
- Install in accordance with IEE wiring regulations and current Building Regulations.
- To prevent electrocution, switch off mains supply before installing or maintaining this fitting. Ensure other persons cannot restore the electrical supply without your knowledge.
- This light fitting should be connected to a circuit with a 30Ma RCD fitted. Maximum 12-15 fittings on each circuit recommended.
- If replacing an existing fitting, make a careful note of the connections.
- All connections should be made as watertight as possible to avoid electrical shortage.
- When changing the bulb, always switch off at the mains & allow to cool before handling.
- Always use the correct type & wattage bulb. Never exceed the wattage stated.
- The unit may get warm whilst on for a period of time.



Voltage: 220 – 240V 50Hz

Max. Wattage: 60W

Bulb Holder: ES / E27

Recommended Bulb: 15w Corn Bulb

IP Rating: IP65

Product Heights: 0.8m / 1.0m above ground + 0.4m below ground (approx.)

Product Finishes: Graphite Black

Product Head Styles: Dome / Flat / Pillar

Materials: Aluminium and Polycarbonate (stainless steel screws)

Mount: Surface Mount

Sensor: PIR (Motion Sensor) ≤8m detection range / 100° detection angle

Sensor Settings: Time Control = 6s, 3m, 5m, 8m / Light Control = 5Lux ≤ all night

Working Temperature/Humidity: -20~+40°C / ≤93%RH

INCLUDED: Root Mount Tube, Bollard Head, Bulb Holder with Connection Box, 3 x Bulb Holder Screws, 1 x Anchor Bar, 2 x Nuts, 2 x Security Pin Hex Screws & Allen Key, M20 Cable Gland, PIR Sensor, LED Lamp (optional).



✓✓✓✓✓
5 YEAR
GUARANTEE

see [website](#) for
more details
Reduced warranty for
specific components

CLEANING:

Occasional cleaning and care is recommended for this product, particularly of the sensor. Please refer to our website for the best way to clean different materials.

RETURNS & RECYCLING:

If purchased from a 3rd party, please contact your supplier. If purchased direct, contact us by phone or email:

Lumena Lights Ltd, Centre 33 Long March, Daventry, NN11 4NR Tel: +44 1327 871161 Email: sales@lumenalights.com

Our full returns policy is available on our website.

Waste Electrical Products must not be disposed of with household waste. Please check with your local authority or contact us for more information. Please recycle packaging whenever possible.

Producer Registration Number: WEE/KC3440XY

SPARES, ALTERNATIVE MOUNTING OPTIONS & ACCESSORIES AVAILABLE FROM LUMENA

Corn Lamps sold separately.

Made in China to Lumena Specification

INSTALLATION:

IMPORTANT: Cable should be laid inside armoured conduit or piping to protect from water-logging, chemicals found in soil and damage. If buried, it should be buried to at least 0.5m below ground to reduce damage risk. If this method is not used, cable warranty will be void.

1. Push the anchor bar through the pre-drilled holes at the base of the tube and secure in place with the 2 x locking nuts provided.
2. Prepare a mounting hole in the desired location to allow for a tube depth of approx. 400mm (can vary depending on the required height above ground). Ensure the diameter of the hole is at least 400mm to accommodate the anchor bar & tube and allow for concrete / earth to be added – Concrete installation recommended. TIP: Carry out placement check, ensuring the pre-drilled sensor hole in the tube will be facing the correct direction for optimum light sensitivity.

For Models with a drainage hole, this must remain above ground.

3. **IF USING CABLE GLAND:** Drill out a 20mm hole at the desired location for cable exit (just above ground height is recommended). Remove the nylon locking nut from the gland. Push the thread through the drilled hole from the outside, ensuring the rubber o-ring is on the outside of the tube, and secure in place with the locking nut inside the tube. Remove the domed cap, push the cable through the cap, threaded gland and then the locking nut. Secure the cap in place, screwing clockwise, when the desired length of cable has been pulled through to reach the bulb holder at the top of the tube with plenty of slack.
4. **WITHOUT CABLE GLAND:** Pull the supply cable up through the bottom of the tube / body of the bollard and then safely reposition in the prepared hole. Double check that the pre-drilled sensor hole in the tube is facing the correct direction.
5. Open the connection box on the bottom of the bulb holder by removing the 2 x cross head screws on the left and right sides. PIR dip switch is located in the secondary junction box, attached to the back of the connection box lid. This does not need to be opened until step 8.
6. Pass the mains cable through the loosened cable entry gland / rubber grommet and wire accordingly – see wiring diagrams below. Check that the supply wires are correctly identified, the connections are tight and that there are no loose strands.
7. Tighten the cable entry gland, replace the lid of the connection box and secure with the 2 x screws removed previously.
8. Pop open the grey junction box to locate the PIR dip switch and PIR sensor.
9. Remove the main sensor with cable & plug from the box.
10. Unscrew the white nut from the back of the main PIR sensor leaving the rubber o-ring of the sensor and carefully pass over the cable plug to completely remove.
11. Pass the sensor through the pre-drilled PIR hole of the tube from the outside, rethread the white nut over the plug and fasten securely in position with the white nut located at the inner tube. The rubber o-ring must be located on the outer side of the tube and not twisted to create a waterproof seal. **IMPORTANT: The embossed arrow on the external sensor MUST face downwards at 180 degrees to ensure correct detection range across the sensor.**
12. Pass the plug and cable through the prepared rubber grommet of the grey junction box and plug into the dip switch
13. Ensure the dipswitch is set to “test mode” (default) – see SETTINGS for more information.
14. Reattach the grey junction box to the lid which is attached to the main connection box by pushing securely – ensure cables cannot be trapped.
15. Flip the bulb holder so that it is facing upwards and rest on top of the bollard tube. Insert E27 light bulb (see LAMP INSTALLATION / REPLACEMENT for further info) and test (see TESTING below).
16. Once tested, isolate the power and adjust dip switch setting as required – see SETTINGS.
17. Secure the bulb holder to the bollard tube, aligning the 3 x holes and secure in place with the 3 x bulb holder screws provided.
18. Carefully place the head over the bulb, being careful not to knock or damage the bulb and check that the holes on each side of the head match those at the top of the tube. **NOTE:** if the holes are not lining up accurately, try rotating the head by 90 degrees.
19. Secure head in place with the 2 pin hex security screws and allen key provided. Alternate screw tightening to prevent misalignment.
20. Mount the Tube into the desired location using supports to hold the fitting upright and checking that it is straight with a spirit level. Concrete or earth must cover the anchor bar and at least 200-300mm above. **Always test prior to setting in concrete for easier access to cable in case of issues.**

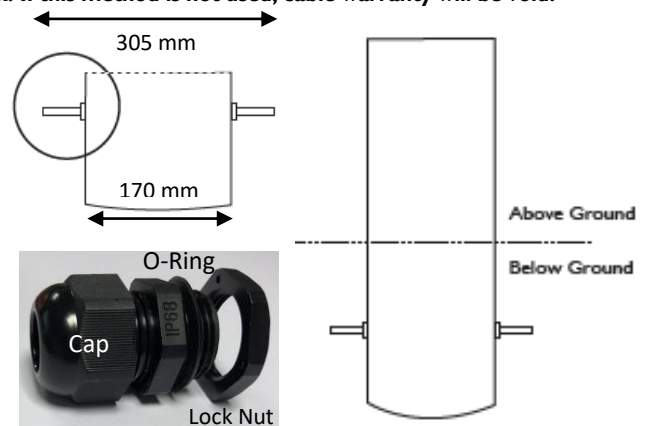

LAMP INSTALLATION / REPLACEMENT: (Ensure power is turned off prior to changing the lamp)

1. If assembled, remove 2 x hex screws from bollard head using the allen key provided.
2. Remove the head by lifting this off the bollard tube / body.
3. Remove / Insert lamp (screw base – E27).
4. Replace head and secure screws with allen key as removed in step '1'. Alternate the tightening of screws to prevent misalignment.

IMPORTANT: Condensation can occur due to the warmth inside the fitting produced by the lamp and the cold air outside. If this is noticed, on a dry day, turn off the power supply, safely remove the head, and wipe dry with a soft cloth.

WIRING DIAGRAMS:

PIR Models are supplied with a 4 way connection block. The fourth connection on the connection block will already be wired to the PIR and one terminal will contain two neutral wires. This should not be changed. Test once wired in default Test Mode.

Some models may include a small length of cable to connect to a junction box at the base of the tube. This can be removed if desired.

TESTING:

- Test on default setting (test mode): 8m, 6 seconds, day and night.
- Power on and leave for 30 seconds until indicator light is flashing once per second and the load turns off.
- Create movement within detection range to ensure the load switches on.
- After approximately 6 seconds of no movement the load should switch off.
- Perform test for a second time prior to adjusting settings.

SETTINGS:

Indicator Light:

- 1) 30 seconds after the first power-on, the sensor will enter the standard induction state – LED flashes once per second
- 2) When the sensor is triggered, the indicator light will light up once.

Default setting (test mode): 8m, 6 seconds, day and night.

Follow the below to select your desired functionality. It is important to adjust the settings to minimum sensitivity for your requirements. If detection range is too sensitive, it may cause unnecessary interference such as from small animals and plants which may reduce the life of the sensor and load.

Detection range based on an ambient temperature of 22-24°C. The higher the ambient temperature, the lower the sensitivity.

Detection range may vary slightly depending on installation height. Detection based on a speed of 1.0-1.5m per second.

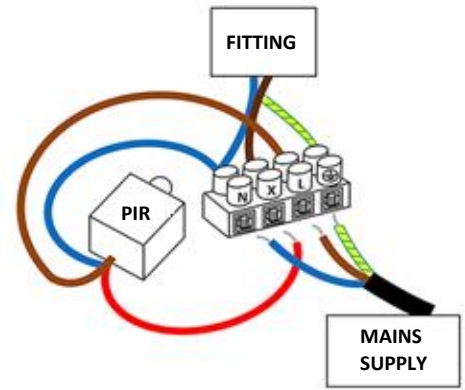

CABLES:

- Neutral (N) = Blue
- Live (L) = Brown
- Earth (⊕) = Yellow & Green
- Live Out (X) = Red (PIR Only)

Colours of wire sleeving may vary slightly – Test prior to use.

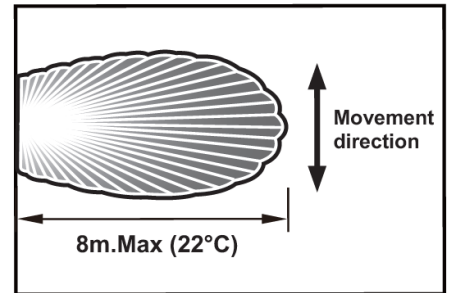

Dip switch

S1	S2	Detection range
0	0	8m
0	1	6m
1	0	4m
1	1	3m

A

A:Detection range

8m 6m
4m 3m

S3	S4	Time setting
0	0	6s
0	1	3min
1	0	5min
1	1	8min

B

B:Time setting

6s 3min
5min 8min

S5	S6	Light-control
0	0	<5LUX
0	1	<20LUX
1	0	<50LUX
1	1	All light

C

C:Light-control

<5LUX <20LUX
<50LUX all light

