



WARNINGS



PLEASE READ THESE INSTRUCTIONS CAREFULLY PRIOR TO INSTALLATION / MAINTENANCE

- If a fitting is found to be damaged, cease use immediately.
- This is a Class I product and must be earthed.
- This unit must be fitted by a competent and qualified electrician.
- Install in accordance with IEE wiring regulations and current Building Regulations.
- To prevent electrocution, switch off mains supply before installing or maintaining this fitting. Ensure other persons cannot restore the electrical supply without your knowledge.
- This light fitting should be connected to a circuit with a 30Ma RCD fitted. Maximum 12-15 fittings on each circuit recommended.
- If replacing an existing fitting, make a careful note of the connections.
- All connections should be made as watertight as possible to avoid electrical shortage.
- The unit may get warm whilst on for a period of time.
- **DO NOT INSTALL INTO THE GROUND BY PUSHING THE HEAD OF THE PRODUCT**



Voltage: 220 - 240v 50Hz

Wattage: 6w

LED: CREE COB I304

IP Rating: IP65

Cable Length: 3 core rubber cable 0.75mm (approx. 0.5m)

Head: Adjustable

Materials: Aluminium & Tempered Glass

Finishes: Black (Powder Coated) / Titanium & Cocoa (Anodised)



✓✓✓
**3 YEAR
GUARANTEE**
see website for
more details

IMPORTANT: Condensation is likely to occur due to the warmth inside the fitting produced by the LED and the cold air outside. If this is noticed, on a dry day, turn off the power supply, safely remove the cap of the head, tip out any excess water and wipe dry with a soft cloth. Replace the head securely, ensuring the rubber o-ring is in place and it is not cross threaded. It is best to avoid opening the fitting, unless condensation needs to be removed, to ensure a watertight seal of IP65.

CLEANING:

Occasional cleaning and care are recommended for this product. Wipe with a soft, slightly damp cloth to remove any surface dirt. Do not use abrasive cleaners or a lot of water as this could damage the fitting. Please refer to our website for more information on the best way to clean different materials.

RETURNS:

If purchased from a 3rd party, please contact your supplier.

If purchased direct, contact us by phone or email:

Lumena Lights Ltd, Centre 33 Long March, Daventry, NN11 4NR

Tel: +44 1327 871161 Email: sales@lumenalights.com

Our full returns policy is available on our website.

Waste Electrical Products should not be disposed of with household waste. Please check with your local authority or contact us for more information. Please recycle packaging whenever possible.

Producer Registration Number: WEE/KC3440XY

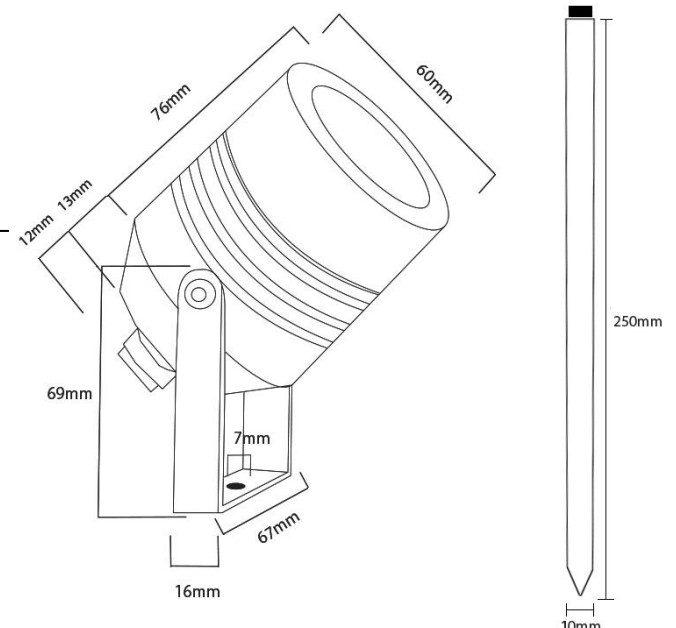

WIRING / CONNECTION:

Always use a waterproof Junction Box or Tubecon Connector to connect the fitting to the mains power supply.

IMPORTANT: Cable should be laid inside armoured conduit or piping to protect from water-logging, chemicals found in soil and damage. If buried, it should be buried to at least 0.5m below ground to reduce damage risk. If this method is not used, cable warranty will be void.

1. Decide on the positioning of the spike light. See below for mounting installation.
2. Locate the mains electrical supply (pre-installed armoured cable).
3. Connect the fitting to the mains supply via a waterproof junction box or Tubecon connector (see diagram A for wiring information).
4. Ensure all terminals of the connector block are secure with no stray wires and that the connection is watertight.
5. Cable supplied with fitting is not armoured, therefore it should be laid inside armoured conduit or hooked up safely out of reach in protective piping.
6. Once fully installed, turn on the mains power.

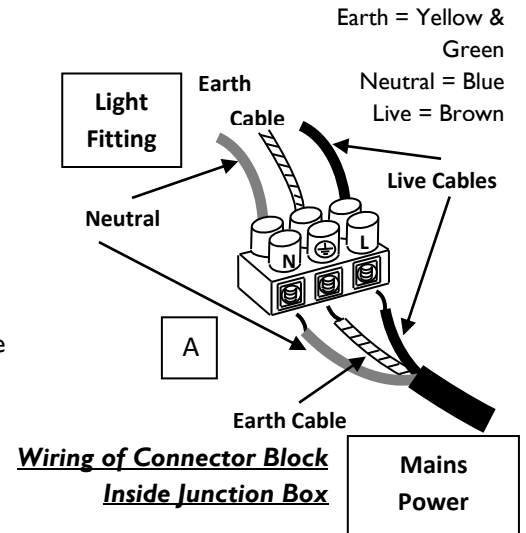

ADJUSTING THE SPOTLIGHT HEAD:

The head can be adjusted and set at various angles via the U Bracket. If this is too secure to move, follow the following steps:

1. Support the head and loosen the 2 x socket screws found on each side of the U Bracket using the allen key provided by turning anti-clockwise – one turn should be enough to allow the head to move up and down (**do not fully remove**).
2. Angle the head in the desired position and tighten the loosened screws to secure in place.
3. If a screw becomes fully removed, return into the outer side of the bracket with a washer on each side as per image (B).

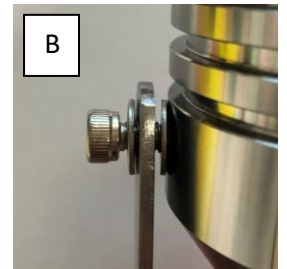

SPIKE MOUNTING:

1. Tilt the spotlight head to create plenty of room between the head and bracket.
2. Remove the socket screw from the ground spike with the allen key provided.
3. Place the spike underneath the U bracket, lining up with the predrilled / threaded holes.
4. Secure the spike to the Bracket with the socket screw / washer by hand, then tighten fully with the allen key provided (image C). **TIP:** for ease of tightening (due to little clearing for the allen key) hold the socket screw securely with the allen key and turn the spike to tighten.
5. Dampen the ground in the area where the fitting is to be installed.
6. Carefully, push the spike into the ground to the desired depth. Do **NOT** put pressure on the spotlight head.
7. Gently compact the earth around the spike to ensure the spike is mounted firmly in the ground and does not move from side to side.
8. Adjust the head to the desired position and secure by tightening the 2 x socket screws on each side of the U Bracket.

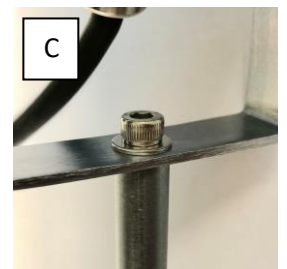

SURFACE MOUNTING:

1. Tilt the spotlight head to create plenty of room between the head and bracket.
2. Hold the bracket in position and mark the desired location for mounting (the head can be fully removed if required).
3. Attach the bracket to the surface with the relevant screws / washers for the material (not supplied) – see image D.
4. If fully removed, reattach the head, as per image B.
5. Adjust the head to the desired position and secure by tightening the 2 x socket screws on each side of the U Bracket.

